

16K Heavy Duty Axle Assembly

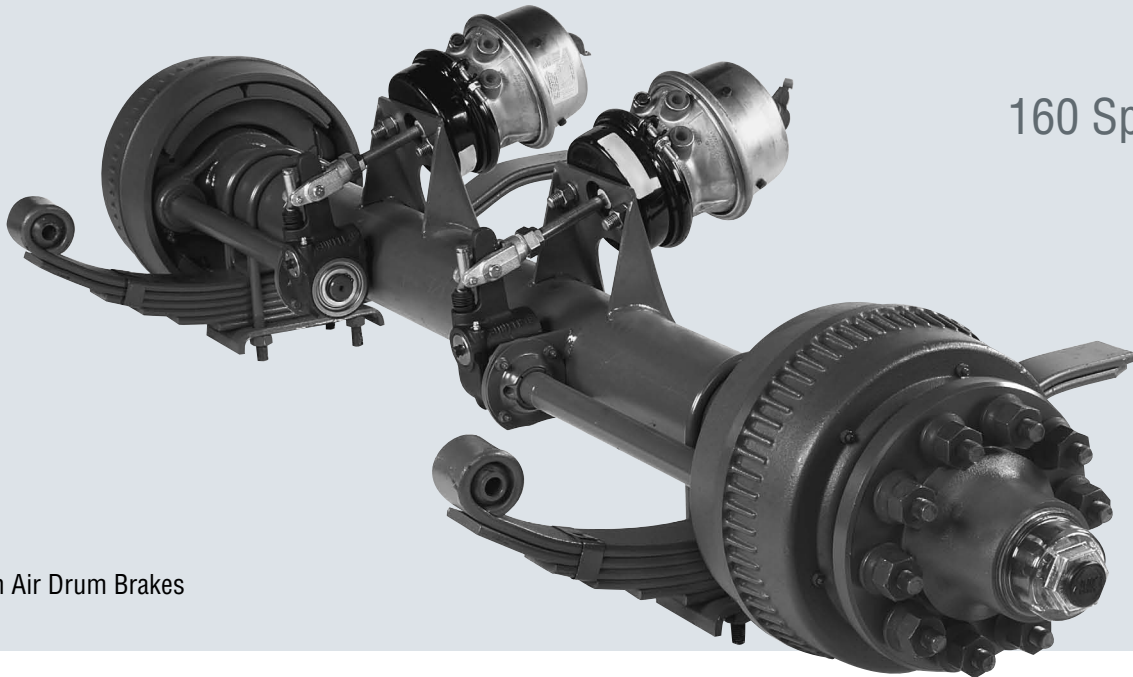

160 Spindle

Shown with Air Drum Brakes

Features

AL-KO's Heavy Duty 16K axle is specifically designed for heavy duty commercial and industrial applications.

5" x 7/16" wall tubing is swaged and friction welded to the 160 spindle creating a weld which is stronger than the base metal.

The two piece hub and drum assembly has a replaceable steel armature for use with electric brakes. AL-KO oil caps are molded from high strength polycarbonate to minimize breakage and leakage. Bearings are lubricated with SAE 90 weight oil to assure long bearing life.

Standard pilot is 6.50 on a 10 bolt on 8.75" bolt circle, using 3/4" swiveling flange nuts. Other wheel fasteners are available upon request.

Standard Specifications

Track❖	74.38"	71.38"	70.38"	68.38"	66.38"
Hub Face	73.50"	70.50"	69.50"	67.50"	65.50"
Spring Center	46.00"	43.00"	42.00"	40.00"	38.00"
Over All	95.25"	92.25"	91.25"	89.25"	87.25"

❖ Track assumes a wheel disc thickness of 1/4".

Part Description

Part Description	AL-KO Part No.
Leaf Spring 6LF/8000 lbs.	—
U-Bolt 5/8" x 10 1/2"	5913
Tie Plate	7708
U-Bolt Nut 5/8" - 11	363851

Available Brake Accessories



ELECTRIC
12 1/4" x 5"

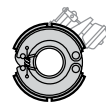

AIR
12 1/4" x 5 1/2"